

# ZANUSSI

## ELECTRIC HOBS

### ZEL 63

INSTRUCTION BOOKLET

Please read this instruction booklet before using the appliance

(GB)

# Important Safety Information



You **MUST** read these warnings carefully before installing or using the hob. If you need assistance, contact our Customer Care Department on 08705 727727

## Installation

- This hob must be installed by qualified personnel, according to the manufacturer's instructions and to the relevant British Standards.
- Remove all packaging before using the hob.
- Ensure that the electrical supply complies with the type stated on the rating plate, located on the bottom of the hob.
- Do not attempt to modify the hob in any way.

## Child Safety

- This hob is designed to be operated by adults. Do not allow children to play near or with the hob.
- The hob gets hot when it is in use.
- Children should be kept away until it has cooled.
- Children can also injure themselves by pulling pans or pots off the hob.

## During Use

- This hob is intended for domestic cooking only. It is not designed for commercial or industrial purposes.
- Do not use this hob if it is in contact with water. Do not operate the hob with wet hands.
- Ensure the control knobs are in the 'OFF' position when not in use.
- When using other electrical appliances, ensure the cable does not come into contact with the hot surfaces of the hob.
- Unstable or misshapen pans should not be used on the hob as unstable pans can cause an accident by tipping or spillage.
- Never leave the hob unattended when cooking with oil and fats.
- Never use plastic or aluminium foil dishes on the hob.
- Perishable food, plastic items and aerosols may be affected by heat and should not be stored above or below the hob unit.

## Service

- This hob should only be repaired or serviced by an authorised Service Engineer and only genuine approved spare parts should be used.

## Environmental Information

- After installation, please dispose of the packaging with due regard to safety and the environment.
- When disposing of an old appliance, make it unusable, by cutting off the cable.

**Keep this instruction book for future reference and ensure it is passed on to any new owner.**

## Guide to Use the instructions

The following symbols will be found in the text to guide you throughout the Instructions:



Safety Instructions



Step by step instructions for an operation



Hints and Tips



Environmental Information



This appliance is manufactured according to the following EEC directives:

- 73/23 EEC
- 90/683 EEC
- 93/68 EEC
- 89/336 EEC current edition.

# Contents

## For the User

Important Safety Information	2
Description of the Hob	3
Operation	4
Maintenance and Cleaning	5
Something Not Working?	6
Service and Spare Parts	6
Customer Care Department	7
Guarantee Conditions	7

## For the Installer

Building In	11
Installation	11
Electrical connections	13
Wiring diagram	14

# Description of the Hob

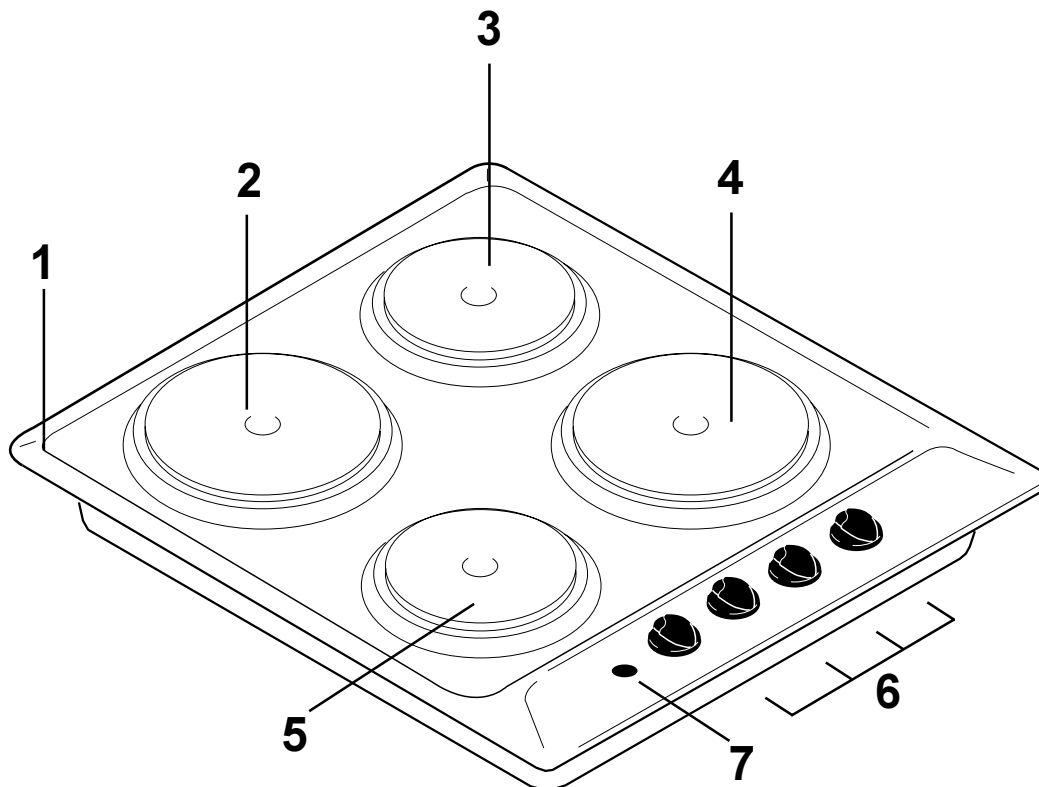

1. Hob Top
2. Normal Hotplate - 1570 W - 180 mm dia.
3. Normal Hotplate - 1040 W - 145 mm dia.
4. Rapid Hotplate - 2090 W - 180 mm dia.
5. Rapid Hotplate - 1570 W - 145 mm dia.
6. Control knobs
7. Electric Hotplates Control Light

# Operation

## Electric Hotplates

To switch on a hotplate, turn the relevant control knob anticlockwise to the required heat setting.

The control knob is numbered 1 - 6

0 - OFF

1 - Minimum

6 - Maximum.

The hob has two types of hotplates:

### Normal Hotplates

We recommend the plates are switched to maximum (6) for a short while to boost the plate, and then adjusted to the required setting.

### Rapid Hotplates

The rapid hotplates are indicated by a red dot, and will heat up more quickly than a normal plate. As the red dots are painted on the plate, they may deteriorate during use and even disappear completely after a period of time. **This will not affect the performance of the hob.**

**i** It is important to note that the plate may smoke and produce a slightly unpleasant odour when used for the first time. This is quite normal and will disappear after a short while.

## Electric Hotplates Control Light

The Hotplates Control Light will come on each time a cooking zone is switched on.

### **i** Hints and Tips

Saucepans for use on solid plates should have several characteristics:

- They should be fairly heavy duty
- They should fit the heat area exactly, or be slightly larger for efficient use, NEVER smaller.
- They should have a flat base to ensure good contact with the plate.  
This is particularly important when using pans for high temperature frying or pressure cooking.

As soon as liquid starts boiling, turn down the plate control knob so that it will barely keep the liquid simmering.

You can switch off the plate a short while before you finish cooking, and the final stage will be completed on the accumulated heat. Similarly, stews etc. cooked in well covered saucepans cook at lower temperature which is more economical.



*Ensure pans are large enough to avoid liquids being spilt onto the plates.*

*Never leave the plates on without a pan on them or with an empty pan on them.*

Suggestions for the correct setting of the plates are given in the following table.

OFF	0	
Very Gentle	1	To keep food warm To melt butter and chocolate
Gentle	2	To prepare cream-sauces, stews and milk puddings or to fry eggs
Slow	3	Dried vegetables, frozen food, fruit, boiling water or milk
Medium	4	Boiled potatoes, fresh vegetables, pâtés, soups, broths, pancakes or fish
High	5	Larger stews, meat roll, fish, omelettes, steaks
Fast	6	Steaks, escalopes and frying.

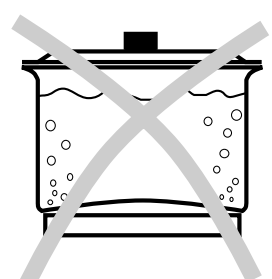
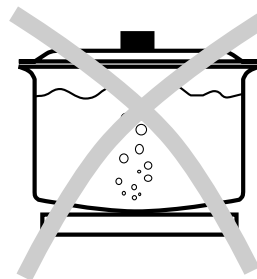
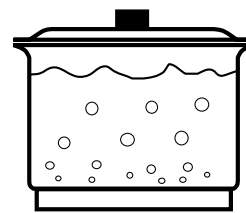



Take care never to lean or reach over a hot electric plate. Always point pan handles inward or over the work surface next to the hob to avoid accidentally knocking over a pan as you pass by.

Take care when frying food in hot oil or fat, as the overheated splashes could easily ignite.

If the control knobs become difficult to turn, please contact your local Zanussi Service Centre.

## Maintenance and Cleaning



Before any maintenance or cleaning can be carried out, you must **DISCONNECT** the hob from the electricity supply.

The hob is best cleaned whilst it is still warm, as spillage can be removed more easily than if it is left to cool.

### The Hob Top

Regularly wipe over the hob top using a soft cloth well wrung out in warm water to which a little washing up liquid has been added. Avoid the use of the following:

- household detergent and bleaches;
- impregnated pads unsuitable for non-stick saucepans;
- steel wool pads;
- bath/sink stain removers.

Should the hob top become heavily soiled, the following products are recommended:

- For stainless steel hobs use a proprietary stainless steel cleaner.
- For other hobs use Hob Brite or Bar Keepers Friend.

The control knobs may be removed by carefully pulling them upward for easier cleaning.

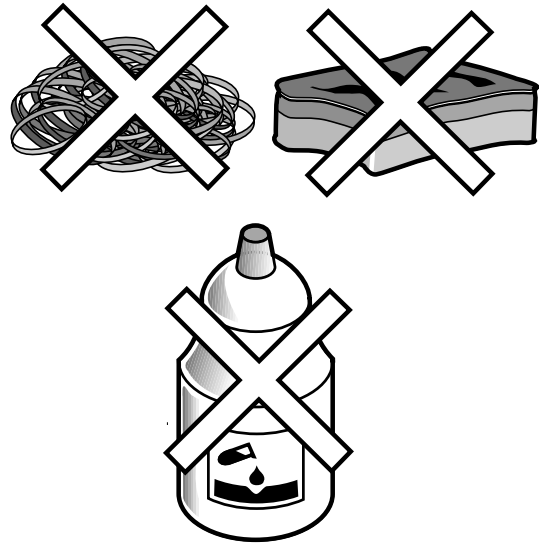

### The Hotplates

Spills onto the actual plate should be removed using warm water and a soft brush, nylon or plastic scourer. To keep the plates looking as new, hotplate conditioner can be purchased from most hardware stores, e.g. "4 Hob" by HomeCare Products (follow the manufacturer's instruction for use).

Alternatively, wipe the plates with a drop of olive oil on a kitchen towel to avoid rust. It is important to note that the plate will smoke a little and produce a slightly unpleasant odour when next used.

**Stainless steel parts:** the stainless steel spill rings may become straw coloured with use. Use a proprietary stainless steel cleaner to remove this straw discolouration. This also applies to the area around the hotplates on stainless steel hobs.



Failure to clean and condition hotplates may lead to rust and corrosion forming on the surface.

# Something Not Working?

If the hob is not working correctly, please carry out the following checks before contacting your local Service Force Centre.

**IMPORTANT:** If you call out an engineer to a fault listed below, or to repair a fault caused by incorrect use or installation, a charge will be made even if the appliance is under guarantee.

SYMPTOM	SOLUTION
■ The plate does not heat up.	<ul style="list-style-type: none"><li>◆ Check that the unit is plugged in and the electrical supply is switched on</li><li>◆ Check that the RCCB has not tripped (if fitted)</li><li>◆ Check the mains fuse has not blown</li><li>◆ Check the correct control knob has been turned.</li></ul>
■ The plate is not giving satisfactory results	<ul style="list-style-type: none"><li>◆ Check the plate is clean and dry</li><li>◆ Check the cooking pan is the correct size for the plate.</li><li>◆ Check the cooking pan has a flat bottom</li><li>◆ Check the setting is correct for the type of cooking.</li></ul>

If after all these checks, your hob still does not operate correctly, contact your local Zanussi Service Force Centre.

**In-guarantee customers should ensure that the above checks have been made as the engineer will make a charge if the fault is not a mechanical or electrical breakdown.**

Please note that it will be necessary to provide proof of purchase for any in-guarantee service calls.

## Service and Spare Parts



In the event of your appliance requiring service, or if you wish to purchase spare parts, please contact your local Zanussi Service Force Centre by telephoning:

**0870 5 929929**

Your telephone call will be automatically routed to the Service Force Centre covering your post code area. The addresses are listed on the following pages.

Before calling out an engineer, please ensure you have read the details under the heading "Something Not Working."

When you contact the Service Force Centre you will need to give the following details:

1. Your name, address and post code
2. Your telephone number
3. Clear and concise details of the fault
4. The model and serial number of the appliance (found on the rating plate)
5. The purchase date

# Customer Care Department

For general enquiries concerning your Zanussi appliance or for further information on Zanussi products, please contact our Customer Care Department by letter or telephone at the address below or visit our website at [www.zanussi.co.uk](http://www.zanussi.co.uk)

## Customer Care Department

Zanussi  
55-77 High Street  
Slough  
Berkshire  
SL1 1DZ  
08705 727727 (\*)

\* calls to this number may be recorded for training purposes.

# Guarantee Conditions

## Zanussi Guarantee conditions

We, Zanussi, undertake that if, within 24 months of the date of the purchase, this Zanussi appliance or any part thereof is proved to be defective by any reason only of faulty workmanship or materials, we will, at our option, repair or replace the same FREE OF ANY CHARGE for labour, materials or carriage on condition that:

- \* The appliance has been correctly installed and used only on the gas and electricity supply stated on the rating plate.
- \* The appliance has been used for normal domestic purpose only, and in accordance with the manufacturer's instructions.
- \* The appliance has not been serviced, maintained, repaired, taken apart or tampered with by any person not authorised by us.
- \* All service work under this guarantee must be undertaken by a Zanussi Service Centre.
- \* Any appliance or defective part replaced shall become the Company's property.
- \* This guarantee is in addition to your statutory and other legal rights.

Home visits are made between **8.30am and 5.30pm** Monday to Friday. Visits may be available outside these hours, in which case a **premium** will be charged.

## Exclusions

**This guarantee does not cover:**

- \* Damage or calls resulting from transportation, improper use or neglect, the replacement of any light bulbs or removable parts of glass or plastic.
- \* Costs incurred for calls to put right an appliance which is improperly installed or calls to appliance outside the United Kingdom.

- \* Appliances found to be in use within a commercial or similar environment, plus those which are the subject to rental agreements.
- \* Products of Zanussi manufacture which are not marketed by Zanussi.

## European Guarantee

If you should move to another country within Europe then your guarantee moves with you to your new home subject to the following qualifications:

- \* The guarantee starts from the date you first purchased your product.
- \* The guarantee is for the same period and to the same extent for labour and parts as exist in the new country of use for this brand or range of products.
- \* This guarantee relates to you and cannot be transferred to another user.
- \* Your new home is within the European Community (EC) or European Free Trade Area.
- \* The product is installed and used in accordance with our instructions and is only used domestically, i.e. a normal household
- \* The product is installed taking into account regulations in your new country.

Before you move, please contact your nearest Customer Care centre, listed below, to give them details of your new home. They will then ensure that the local Service Organisation is aware of your move and able to look after you and your appliances.

France	Senlis	+33 (0)3 44 62 29 99
Germany	Nürnberg	+49 (0)911 323 2600
Italy	Pordenone	+39 (0)1678 47053
Sweden	Stockholm	+46 (0)8 738 79 50
UK	Slough	+44 (0)1753 219897

To contact your local Zanussi Service Force Centre telephone 08705 929 929

<b>CHANNEL ISLANDS</b>				<b>NORTH EAST</b>	
GUERNSEY	Guernsey Electricity PO Box 4 Vale, Guernsey Channel Islands	ORKNEY (M65)	Corsie Domestics 7 King Street Kirkwall Orkney KW15	GATESHEAD (M39)	Unit 356a Dukesway Court Dukesway Team Valley Gateshead NE11 0BH
JERSEY	Jersey Electricity Company PO Box 45 Queens Road St Helier Jersey Channel Islands JE4 8NY	PERTH	Hydro Electrical Inveralmond House Ruthervenfield Road Perth PH1 3AQ	GRIMSBY (M42)	15 Hainton Avenue Grimsby South Humberside DN32 9AS
<b>SCOTLAND</b>		PERTH (OWN SALES)	Graham Begg Unit 4 Airport Ind Estate Wick KW1 4QS	HULL (M41)	Unit 1 Boulevard Industrial Estate Hull HU3 4AY
ABERDEEN (M05)	54 Claremont Street Aberdeen AB10 6RA	SHETLAND (OWN SALES)	Tait Electronic Systems Ltd Holmsgarth Road Lerwick Shetland ZE1 0PW	LEEDS (M37)	64-66 Cross Gates Road Leeds LS15 7NN
AUCHTERMUCHY (M03)	33a Burnside Auchtermuchy Fife KY14 7AJ	SHETLAND (OWN SALES)	Bolts Shetland Ltd. 26 North Road Lerwick Shetland ZE1 0PE	NEWTON AYCLIFFE (M45)	Unit 16 Gurney Way Aycliffe Industrial Estate Newton Aycliffe DL5 6UJ
BLANTYRE (M07)	Unit 5 Block 2 Auchenraith Ind. Estate Rosendale Way Blantyre G72 0NJ	WHALSAY (OWN SALES)	Leask Electrical Harisdale Symbister, Whalsay Shetland ZE2 9AA	SHEFFIELD (M38)	Pennine House Roman Ridge Ind. Roman Ridge Road Sheffield S9 1GB
DUMFRIES (M01)	93 Irish Street Dumfries Scotland DG1 2 PQ	<b>NORTHERN IRELAND</b>		<b>NORTH WEST</b>	
DUNOON (M67)	Brair Hill 7 Hill Street Dunoon Argyll PA23 7AL	BELFAST (M27)	Owenmore House Kilwee Business Park Upper Dunmury Lane Belfast BT17 0HD	BIRKENHEAD (M11)	1 Kelvin Park Dock Road Birkenhead L41 1LT
GLASGOW (M04)	20 Cunningham Road Clyde Estate Rutherglen Glasgow G73 1PP	<b>WALES</b>		CARLISLE (M10)	Unit 7 James Street Workshops James Street Carlisle Cumbria CA2 5AH
INVERNESS (M06)	Unit 3B Smithton Ind. Estate Smithton Inverness IV1 AJ	CARDIFF (M28)	Guardian Industrial Estate Clydesmuir Road Tremorfa Cardiff CF2 2QS	ISLE OF MAN (M64)	South Quay Ind. Estate Douglas Isle of Man IM1 5AT
ISLE OF ARRAN  (OWN SALES)	Arran Domestics Unit 4 The Douglas Centre Broddick Isle of Arran KA27 8AJ	CLYWD (M14)	Unit 6-7 Coed – Parc Abergele Road Rhuddlan Clwyd Wales LL18 5UG	LIVERPOOL (M15)	Unit 1 Honeys Green Precinct Honeys Green Lane Liverpool L12 9JH
ISLE OF BARRA  (OWN SALES)	J Zerfah 244 Bruernish Isle of Barra Western Islands HS9 5QY	DYFED (M77)	Maes Y Coed High Mead Llanybydder Carmarthenshire SA40 9UL	MANCHESTER (M09)	Unit B Central Industrial Estate St Marks Street Bolton BL3 6NR
ISLES OF BUTE (M66)	Walker Engineering Glenmhor Upper Serpentine Road Rothesay Isle of Bute PA20 9EH	HAVERFORDWEST (M75)	Cromlech Lodge Ambleston Haverfordwest Pembrokeshire SA62 5DS	PRESTON (M13)	Unit 250 Dawson Place Walton Summit Bamber Bridge Preston Lancashire PR5 8AL
ISLE OF LEWIS (M69)	ND Macleod 16 James Street Stornoway Isle of Lewis PA87 2QW	OSWESTRY (M17)	Plas Ffynnon Warehouse Middleton Road Oswestry SY11 2PP	STOCKPORT (M16)	Unit 20 Haigh Park Haigh Avenue Stockport SK4 1QR
KELSO (M08)	2-8 Wood Market Kelso Borders TD5 7AX				



To contact your local Zanussi Service Force Centre telephone 08705 929 929

MIDLANDS		LONDON & EAST ANGLIA		SUNBURY (M63)	Unit 1a The Summit Hanworth Road Hanworth Ind. Estate Sunbury on Thames TW16 5D
BIRMINGHAM (M18)	66 Birch Road East Wyrley Road Ind. Estate Witton Birmingham B6 6DB	BECKENHAM (M79)	11a Gardener Ind. Estate Kent House Lane Beckenham Kent BR3 1QZ		
BOURNE (M44)	Manning Road Ind. Estate Pinfold Road Bourne PE10 9HT	CHELMSFORD (M47)	Hanbury Road Widford Ind. Estate Chelmsford Essex CM12 3AE		<b>SOUTH EAST</b>
BRIDGNORTH (M72)	68 St. Mary's Street Bridgnorth Shropshire WV16 4DR	COLINDALE (M53)	Unit 14 Capitol Park Capitol Way Colindale London NW9 0EQ	ASHFORD (M58)	Unit 2 Bridge Road Business Est. Bridge Road Ashford Kent TN2 1BB
GLOUCESTER (M23)	101 Rycroft Street Gloucester GL1 4NB	ELTHAM (M78)	194 Court Road Mottingham Eltham London SE9 4EW	FLEET (M59)	Unit 1 Redsfield Ind. Estate Church Crookham Fleet Hampshire GU13 0RD
HEREFORD (M31)	Unit 3 Bank Buildings Cattle market Hereford HE4 9HX	ENFIELD (M49)	284 Alma Road Enfield London EN3 7BB	HAYWARDS HEATH (M55)	21-25 Bridge Road Haywards Heath Sussex RH16 1UA
HIGHAM FERRERS (M51)	30 High Street Higham Ferrers Northants NN10 8BB	GRAVESEND (M57)	Unit B4 Imperial Business Estate Gravesend Kent DA11 0DL		<b>SOUTH WEST</b>
ILKESTON (M43)	Unit 2 Furnace Road Ilkeston DE7 5EP	HARPENDEN (M46)	Unit 4 Riverside Estate Coldharbour Lane Harpenden AL5 4UN	BARNSTAPLE (M30)	Main Road Fremington Barnstaple North Devon EX31 2NT
LEICESTER (M22)	Unit 7 Oaks Ind. Estate Coventry Road Narborough Leicestershire LE0 5GF	LETCHWORTH (M50)	16-17 Woodside Ind. Estate Works Road Letchworth Herts SG6 1LA	BOURNEMOUTH (M26)	63-65 Curzon Road Bournemouth Dorset BH1 4PW
LINCOLN (M40)	Unit 8 Stonefield Park Clifton Street Lincoln LN5 8AA	LONDON (M76)	2/4 Royal Lane Yiewsley West Drayton Middlesex UB7 8DL	BRIDGEWATER (M35)	6 Hamp Ind. Estate Bridgewater Somerset TA6 3NT
NEWCASTLE UNDER LYME (M12)	18-21 Croft Road Brampton Ind. Estate Newcastle under Lyme Staffordshire ST5 0TW	MAIDENHEAD (M60)	Reform Road Maidenhead Berkshire SL6 8BY	BRISTOL (M25)	11 Eldon Way Eldonwall Trading Bristol Avon BS4 3QQ
REDDITCH (M20)	13 Thornhill Road North Moons Moat Redditch Worcestershire B98 9ND	MOLESEY (M61)	10 Island Farm Avenue West Molesey Surrey KT8 2UZ	EMSWORTH (M33)	266 Main Road Southbourne Emsworth PO10 8JL
TAMWORTH (M19)	Unit 3 Sterling Park Claymore Tamworth B77 5DO	NEWBURY (M24)	9 Pipers Court Berkshire Drive Thatcham Berkshire RG19 4ER	ISLE OF WIGHT (M34)	Unit 8 Enterprise Court Ryde Business Park Ryde Isle of Wight PO33 1DB
WORCESTER (M73)	Units 1 & 2 Northbrook Close Gregorys Mill Ind. Estate Worcester WR3 8BP	IPSWICH (M48)	Unit 6C Elton Park Business Centre Hadleigh Road Ipswich IP2 0DD	NEWTONABBOT (M29)	Unit 2 Zealley Ind. Estate Kingsteignton Newton Abbot S. Devon TQ12 3TD
		NORWICH (M52)	2b Trafalgar Street Norwich NR1 3HN	REDRUTH (M36)	Unit 7D Pool Ind. Estate Wilson Way Redruth Cornwall TR15 3QW

# Instructions for the Installer

## Engineers technical data

### Heating elements Ratings

Normal front left Hotplate	Ø 180 mm	1570 W
Normal back left Hotplate	Ø 145 mm	1040 W
Rapid front right Hotplate	Ø 145 mm	1570 W
Rapid back right Hotplate	Ø 180 mm	2090 W
Total rating		6270 W

### Cut out dimensions

Width:	550 mm.
Depth:	470 mm.

### Overall dimensions

Width:	580 mm.
Depth:	500 mm.

## Important safety requirements

This hob must be installed in accordance with the IEE Wiring Regulations (Current Edition).

Detailed recommendations are contained in the following British Standards Codes Of Practice: B.S. 6172/ B.S. 5440, Par. 2 and B.S. 6891 Current Editions.

## Location

This hob has been registered as a "Class X" appliance according to Fire Risk Regulations. Minimum distances detailed below must be observed. The hob may be located in a kitchen, a kitchen/diner or bed sitting room, but not in a bathroom or shower room.

Before making the cut out in the worktop ensure that there is a minimum distance of 55 mm. between the rear edge of the hob and the wall. A minimum distance of 100 mm. must be left between the side edges of the hob and any adjacent cabinets or walls.

The minimum distance combustible material can be fitted above the hob in line with the edges of the hob is 400 mm. If it is fitted below 400 mm. a space of 50 mm. must be allowed from the edges of the hob.

The minimum distance combustible material can be fitted directly above the hob is 700 mm.

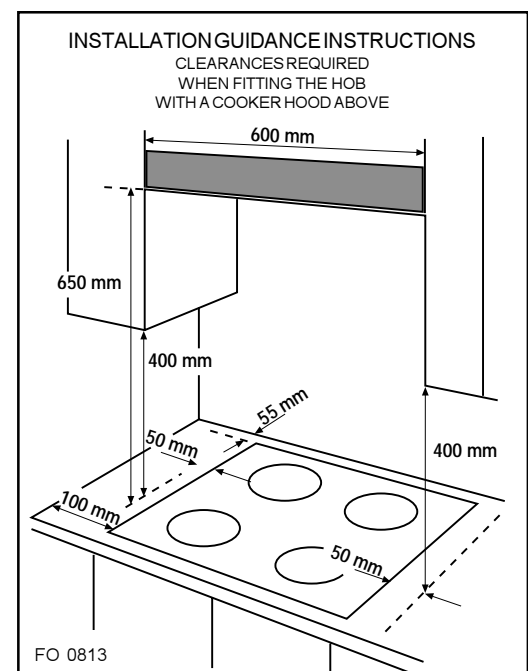
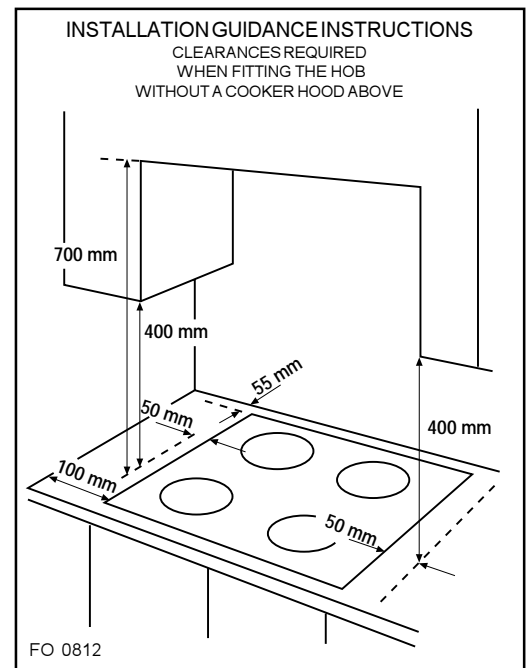

# Installation



The hob must be installed according to the instructions supplied.

The hob must be installed by **qualified personnel** to the relevant British Standards.

Please, ensure that, once the hob is installed, it is easily accessible for the engineer in the event of a breakdown.

## Cut Out Size

The dimensions of the cut-out are given in the diagram.

## Supply connections

This hob is designed to be connected to 230-240 V (50Hz) electricity supply.

The hob has a terminal block which is marked as follows:

L - Live terminal  
N - Neutral terminal

 or E - Earth terminal

The cable used to connect the hob to the electrical supply must be 6mm, PVC twin and earth, and fused to 30amp.

It is necessary that you install a double pole switch between the hob and the electricity supply (mains), with a minimum gap of 3mm between the switch contacts and of a type suitable for the required load in compliance with the current rules.

The switch must not break the yellow and green earth cable at any point.

# Building In

## Building over a cupboard or drawer

If the hob is to be installed above a cupboard or drawer it will be necessary to fit a heat resistant board below the base of the hob on the underside of the work surface.

It is also recommended to carry out the electrical connection to the hob as shown in diagrams 1 and 2.

## WHEN THE HOB IS FIRST INSTALLED



Once the hob has been installed, it is important to remove any protective materials, which were put on in the factory.

The manufacturer will not accept liability, should the above instructions or any of the other safety instructions incorporated in this book be ignored.

## Rectangular cut-out size for hob

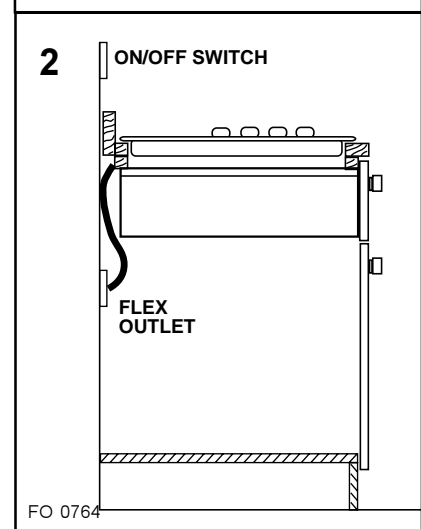
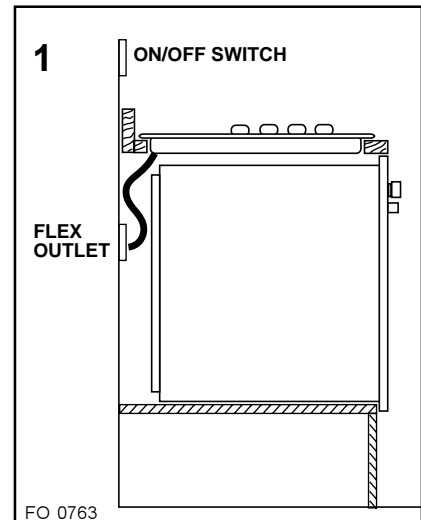
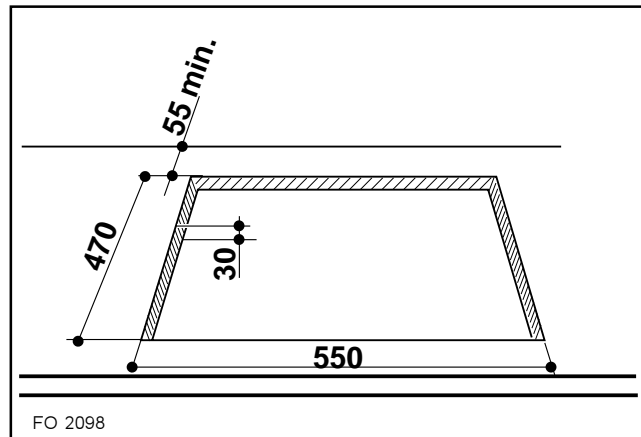

## Building over a kitchen unit with door

Proper arrangements must be taken in designing the furniture unit, in order to avoid any contact with the bottom of the hob which can be hot when in operation. The recommended solution is shown in diagram 3.

The panel fitted under the hob ("a") should be easily removable to allow easy access if technical assistance is needed. The space behind the kitchen unit ("b") can be used for connections.

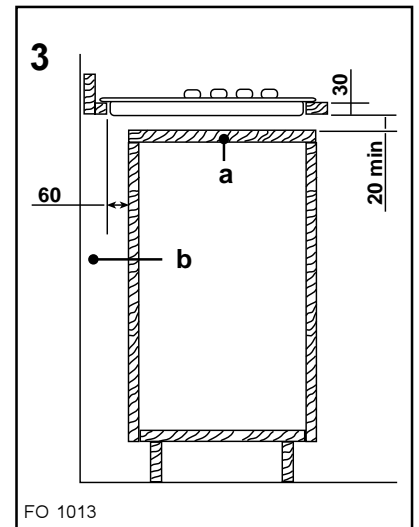

Dimensions are given in mm.

## Fitting the Hob into the worktop

Carry out the building in of the hob as follows:

- put the seals supplied with the hob, on the edges of the cut out: place them exactly on the front and rear edge and at 50 mm. from the side edges, taking care that the seals meet without overlapping;
- place the hob in the cut out, taking care that it is centred;
- fix the hob with the relevant fixing clamps and screws, as shown in the diagram. When the screws have been tightened, the excess seal can be removed.

The edge of the hob forms a double seal which prevents the ingress of liquids.

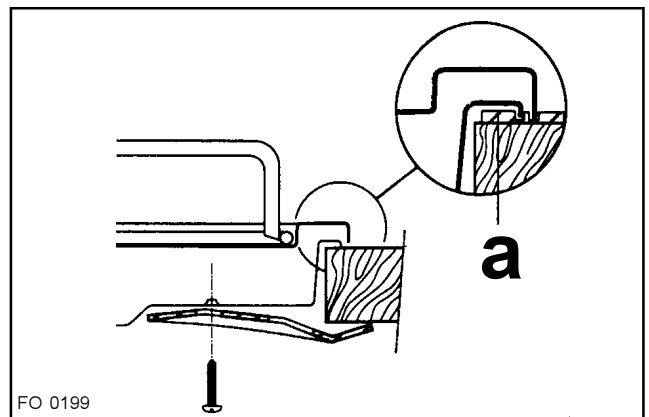

a) Sealing gasket

# Electrical connections



Any electrical work required to install this hob should be carried out by a qualified electrician or competent person, in accordance with the current regulations.



## THIS HOB MUST BE EARTHED.

The manufacturer declines any liability should these safety measures not be observed.

This hob is designed to be connected to a 230-240V 50Hz AC electrical supply.

Before switching on, make sure the electricity supply voltage is the same as that indicated on the hob rating plate. The rating plate is located on the bottom of the hob. A copy is attached on the back cover of this book.

The hob is supplied without supply cord. A 3 core flexible supply cord must be fitted, in accordance with the specification given in the relevant tables.

- 1) Remove the mains terminal cover plate from the underside of the hob, to expose the mains terminal block.
- 2) Loosen the two cable clamp screws and lift the top section of the clamp enough to allow the cable to be passed through.
- 3) Connect the red (live) wire to the terminal which is marked with the letter "L".
- 4) Connect the black (neutral) wire to the terminal which is marked with the letter "N".
- 5) After fitting a green or yellow/green sleeve over the bare copper wire (earth wire), connect the exposed end to the terminal which is marked with the earth symbol  or with the letter "E" coloured green and yellow.

### NOTE:

The earth wire should be about 2 cm. longer than the live and neutral wires.

- 6) Secure the cable by means of the clamp screws and refit the terminal block cover.

The hob should be connected to a double pole switch with a minimum gap of 3 mm. between the switch contacts and of a type suitable for the required load in compliance with the current electric regulations. The switch should be sited within 2m of the hob and be easily accessible upon completion of the installation.

The switch must not break the yellow and green earth cable at any point.



Ensure that the hob supply cord does not come into contact with surfaces with temperatures higher than 50 deg. C.

## Supply Cable Specifications

### For Uk use only

Connection via	Min. size Cable/flex	Cable / flex type	Fuse
• Cooker Control Circuit	6 mm <sup>2</sup>	PVC/PVC twin and earth	30 A

### For Europe use only

Min. size Cable/flex	Cable / flex type	Fuse
2.5 mm <sup>2</sup>	H05 RR-F	30 A

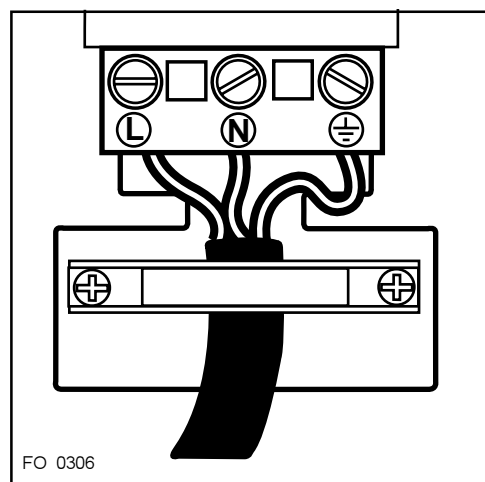

# Wiring diagram

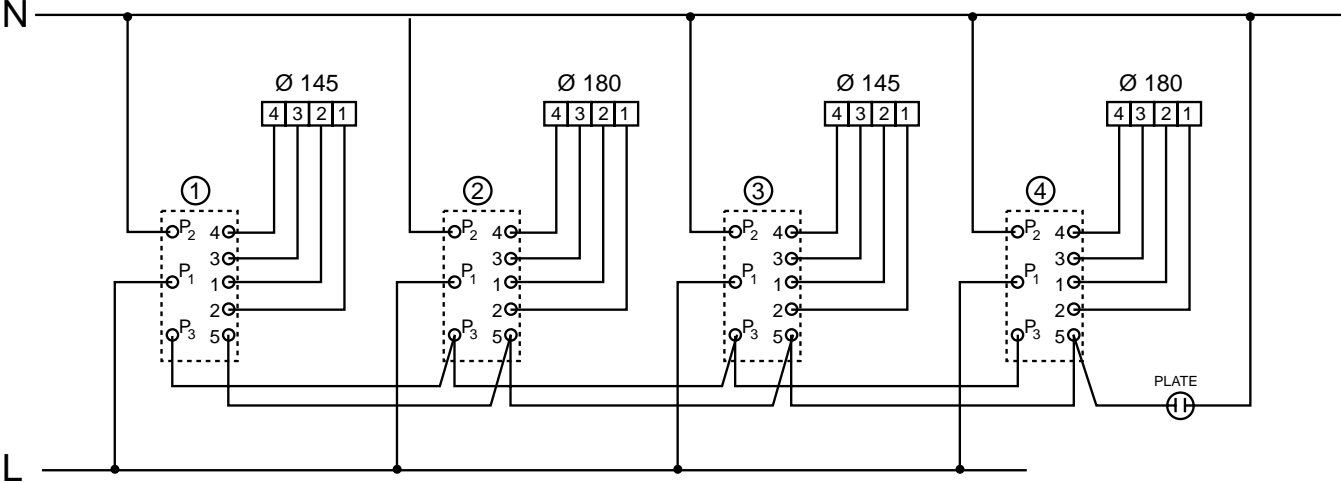



## CUSTOMER CARE

### Zanussi

55-77 High Street  
Slough  
Berkshire, SL1 1DZ  
Tel: 08705-727727

© Electrolux Household Appliances Limited 2000

 **From the Electrolux Group.** *The world's No.1 choice.*

*The Electrolux Group is the world's largest producer of powered appliances for kitchen, cleaning and outdoor use. More than 55 Group products (such as refrigerators, cookers, washing machines, vacuum cleaners, chain saws and lawn mowers) are sold each year to a value of approx. USD 14 billion in more than 150 countries around the world.*